

Vehicle Technology  
**QUALITY FOR LIFE**

**AL-KO**



# AL-KO ESC USER MANUAL

OPERATING INSTRUCTIONS

WARRANTY DETAIL



## About AL-KO ESC

The new AL-KO ESC (Electronic Stability Control) is a sway and swerve stability control system for caravans fitted with AL-KO electric brakes. The ESC gives an assurance to drivers that, even in the most difficult of driving scenarios, the stability of their caravan is being monitored by the ESC, providing an unparalleled level of safety during the journey. Manoeuvring past heavy goods vehicles, coping with excessive side winds and dealing with road hazards can be done with the ultimate confidence that any potentially dangerous condition will be controlled smoothly and effectively by the ESC.



The ESC is only approved for use on trailers and caravans fitted with AL-KO electric brakes, axles and approved suspensions.

## How it works

AL-KO ESC is an ingenious electronic braking system that works in a similar way to an ESC system in some cars. The AL-KO ESC constantly senses the lateral (side to side) movement of the caravan while towing. When a critical sway or emergency swerve is detected, the ESC partially applies the caravan brakes. Braking of the caravan only has the effect of pulling the caravan into line behind the tow vehicle and prevents further swaying of the caravan. This allows the driver to remain in control of the vehicle.

Critical swerve or sway is detected by the ESC



ESC partially applies the caravan brakes. The caravan is pulled into line behind the tow vehicle



The sway is stopped and the caravan brakes are released





## Instructions for use

The ESC must be connected to the power supply in the tow vehicle using a 12 pin trailer connector or separate 2 pin connector. The ESC automatically completes a self test when power is connected to check that everything is working and connected correctly. The LED status light, located at the front of the caravan, will display red during the test. Once the test is complete, the LED status light will turn green.

The ESC is then operational and ready for use.

Occasionally the LED will flash green and then requires some movement to complete the test, if this occurs the vehicle should be driven a short distance and the LED status light rechecked for a solid green LED to make sure that the system is working correctly.

When a sway or swerve occurs during your trip, the ESC will detect the critical movement of the caravan and the ESC will automatically activate the brakes to a preset amount.

If the LED status light turns red at any time a minor problem has been detected. It is safe to drive but the ESC will not activate during a critical sway or swerve until the problem has been addressed and the green light restored. Refer to the Troubleshooting section to determine the corrective steps.

If the LED status light flashes red continuously at 1 second intervals, a serious problem has been detected and the ESC will no longer operate. The ESC should not be used and must be disconnected before driving further. Refer to the Troubleshooting section to determine the next steps.

### Off road use:

The ESC should be disconnected for serious off road use because the severe tilting of the trailer and bumps experienced during off road driving may cause the ESC to inadvertently activate the brakes.

For vehicles intended to be taken on extreme off road use it is recommended that the ESC is connected to the tow vehicle using a separate 2 pin connector rather than the normal 12 pin connector.

This enables the user to disconnect the ESC during these periods of extreme off road use. The ESC should be immediately re-connected when on less severe road conditions. AL-KO ESC is safe to use on un paved roads.



### Maintenance

The connector on the caravan and tow vehicle must be lubricated with a water dispersant spray and checked regularly for corrosion to ensure that the ESC will function correctly. Replace the connector once it displays evidence of corrosion. Otherwise the ESC is maintenance free and requires no adjustment. Note that the electric brakes must be adjusted correctly and working well for the ESC to operate effectively. Maintenance of your electric brakes is important and should be carried out as described in the electric brake service manual.

### Frequently asked questions

Q. How do I know if the ESC has activated?

A. Soft braking of the caravan should be noticed in the car.

Q. Do the caravan brake lights function when the ESC is activated during a manoeuvre?

A. No. Neither do the brake lights on your tow vehicle when its ESC is activated. The ESC applies the caravan brakes to correct alignment rather than to stop the combination, so stop light illumination is not appropriate.



LED status light



## Troubleshooting

The ESC will indicate if there are any problems with the system by changing the LED status light to red for minor problems or flashing red for a serious problem.

### Red Status Light

Disconnect the ESC for 10 seconds and then reconnect.

If the red light remains on, then check for the following problems:

Loose contacts	
Check that the ESC is connected properly and that the connectors are not dirty or corroded.	Clean or replace the connector and terminals.
Check that the power cables to the ESC are in good condition and are not damaged.	Repair damaged cable or replace loom.
Check that the ESC module under the caravan has not become dislodged.	Reattach the ESC firmly in the correct location.
Electric brakes are not all connected	
Check that the ESC is connected to AL-KO electric brakes.	Fit AL-KO electric brakes
Check that ALL the brakes are connected correctly.	Reconnect or replace brakes as required.
Check that the brake magnets are not damaged.	Repair or replace if necessary.
Under voltage/over voltage	
Check that the tow vehicle is fitted with a 12 volt battery.	Use only tow vehicles with 12 volt batteries.
Check that the power is supplied directly from the tow vehicle battery and the connection to the battery is good.	Reconnect the power supply directly to the battery.
The 12 pin connector may have poor connection or the cables in the tow vehicle may be damaged or undersized. Check with a voltmeter that 12 volts is reaching the 12 pin connector at the rear of the tow vehicle.	Repair any damaged cables. Clean the 12 pin connector. Replace cables and/or connector if required.
The ESC connector may have poor connection or the cables in the caravan may be damaged. Check with a voltmeter that 12 volts is reaching the connector at the ESC under the caravan. Measure the voltage at the ESC connector, the power supply contacts are shown below.	Clean the connector. Replace the connector if necessary. Repair any damaged cables or replace cables if necessary.

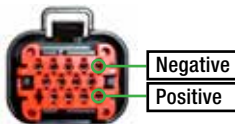

After completing each check, reconnect the ESC. When the LED status light turns green the ESC is fully functional and the caravan is safe to tow.



## Flashing Red Status Light

If the ESC status light flashes red constantly each second, disconnect the ESC before driving by unplugging the connector to the ESC under the caravan. Contact AL-KO and return the ESC module for repair or replacement.

If the ESC status light flashes red very quickly occasionally when the ESC has no power, this is feedback from the brake controller and is not a problem.

## Status Light is OFF

No power to the ESC	
Check that the 12 pin connector is plugged in to the tow vehicle.	Reconnect the 12 pin connector.
Check that ESC connector is plugged into the ESC under the caravan.	Reconnect the ESC connector.
No power supplied from tow vehicle. Check for 12 volts at the 12 pin connector & check fuse or circuit breaker.	Repair any damaged cables. Clean the 12 pin connector. Replace fuse if required. Replace cables and/or connector if required.
No power at ESC connector. Check for 12 volts at ESC connector.	Clean the connector. Repair any damaged caravan cables or replace if necessary
Check that the cables are not damaged.	Repair or replace the cables if necessary.
LED status light is faulty	
Check voltage supplied to the light is two volts	Replace LED status light

## Flashing Green Status Light

A flashing green light indicates that the start up test has been completed but the ESC has not yet detected any movement to confirm that the sensors are working. The ESC will switch to solid green once the ESC detects movement. If the flashing green light continues constantly, contact AL-KO.

## ESC Layout

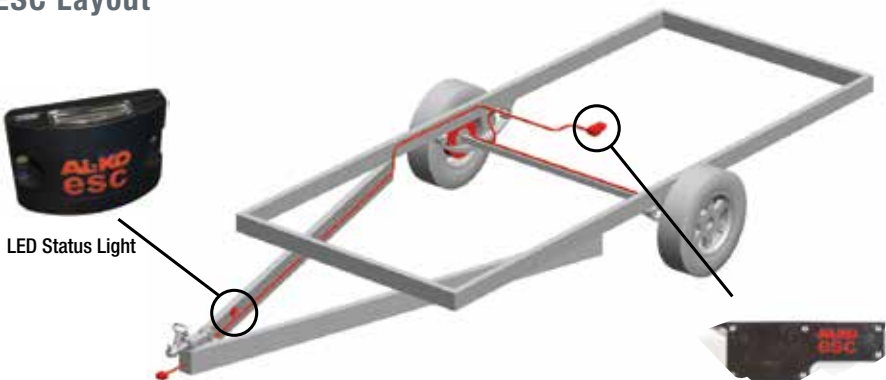

LED Status Light



## Electric Brake Wiring Diagram

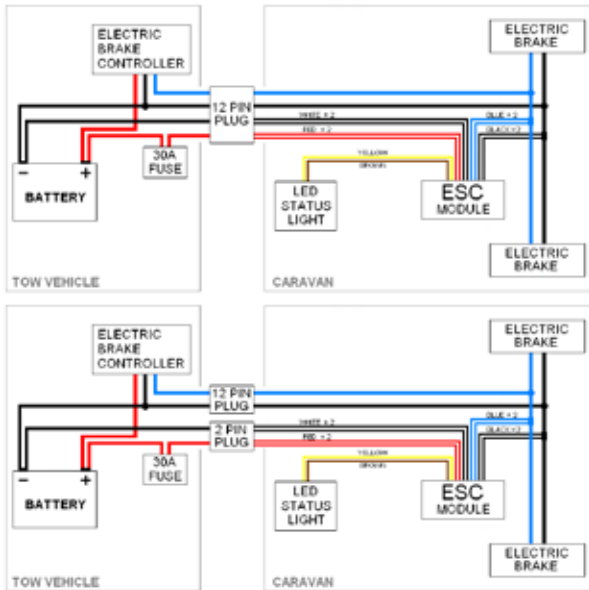

**Option 1 - ESC power supply via 12 pin connector**

**Option 2 - ESC power supply via 2 pin connector**

## Vehicle Wiring

The tow vehicle which will be used to tow your caravan or trailer fitted with the ESC must have the power supply for the ESC wired directly to the battery and a 30A fuse or circuit breaker fitted.

The ESC should be connected to the tow vehicle using a standard 12 pin plug or 2 pin connector. The layout for a 12 pin plug varies between manufacturers, contact the manufacturer of your caravan to confirm how your caravan is wired.

For off road use it is recommended that the ESC is connected to the tow vehicle using a 2 pin plug such as a 50AMP connector to disconnect the ESC for periods of extreme off road driving. A 2 pin connector can be supplied by AL-KO if required (Part number: 350350).

The tow vehicle should be fitted with an approved electric brake controller listed below:

- Tekonsha Prodigy P2
- Tekonsha Primus IQ
- Hayes Energiser III
- Tekonsha P3
- Tekonsha Prodigy
- Hayman Reese Guardian IQ

## 12 pin connector wiring

*\*(Check with caravan manufacturer as to which pins have been used for ESC)*

PIN # *	Cable Colour	Description
	Red	ESC Power supply – 2 red cables
10	White	ESC Earth – 2 white cables



Plug – caravan/trailer

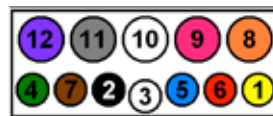

Socket – tow vehicle



## AL-KO International Pty Ltd Warranty

Our goods come with guarantees that cannot be excluded under the Australian Consumer Law. You are entitled to a replacement or refund for a major failure and for compensation for any other reasonably foreseeable loss or damage. You are also entitled to have the goods repaired or replaced if the goods fail to be of acceptable quality and the failure does not amount to a major failure.

AL-KO International Pty Ltd (ABN 96 003 066 813) ("AL-KO") provides the following warranty in relation to its Electronic Stability Control or ESC ("Product").

The benefits of this warranty are in addition to any rights and remedies imposed by Australian State and Federal legislation that cannot be excluded. Nothing in this warranty is to be interpreted as excluding, restricting or modifying any State or Federal legislation applicable to the supply of goods and services which cannot be excluded, restricted or modified.

### WARRANTY

AL-KO warrants that, subject to the exclusions and limitations below, the Product will be free from defects in materials and workmanship for a period of 12 months or 20,000 km, whichever occurs first, from date of purchase. This warranty is not transferable to a subsequent person if the Product is sold by the original purchaser during the warranty period.

If a defect appears in the Product before the end of the warranty period and AL-KO finds the Product to be defective in materials or workmanship, AL-KO will, in its sole discretion, either:

- (a) replace or repair the Product or the defective part of the Product free of charge; or
- (b) cause the Product or the defective part of the Product to be replaced or repaired by a qualified repairer free of charge.

AL-KO reserves the right to replace defective parts of the Product with parts and components of similar quality, grade and composition where an identical part or component is not available.

Goods presented for repair may be replaced by refurbished goods of the same type rather than being repaired. Refurbished parts may be used to repair the goods.

### WARRANTY CLAIMS

1. If a fault covered by warranty occurs, the customer must within 7 days contact the dealer from which the Product was purchased, or AL-KO at the contact address listed below.
2. Any warranty claim must be accompanied by:

- (a) proof of purchase;
- (b) full details of the alleged defect; and
- (c) any relevant documentation (such as maintenance records).

3. The customer must make the Product available to AL-KO or its authorised repair agent for inspection and testing within 14 days of contacting AL-KO or the dealer in accordance with this warranty claims procedure. If inspection and testing finds no defect in the Product, the customer must pay AL-KO's costs of service work and testing.

4. The cost of transportation to or from AL-KO or the authorised repair agent is to be paid by the customer.

### EXCLUSIONS

The warranty will not apply where:

- (a) the Product has been repaired, altered or modified by someone other than AL-KO or an authorised repair agent;
- (b) the Product was improperly installed;
- (c) AL-KO cannot establish any fault in the Product after testing and inspection;
- (d) the Product has been used other than for the purpose for which it was designed;
- (e) the defect in the Product has arisen due to the customer's failure to properly use and maintain the Product in accordance with AL-KO's instructions, recommendations and specifications (including maintenance);
- (f) the Product has been subject to abnormal conditions, including environment, temperature, water, fire, humidity, pressure, stress or similar;
- (g) the defect has arisen due to abuse, misuse, neglect or accident;
- (h) the defect has arisen due to a power surge or other fault in the supply of electricity; or
- (i) unauthorised parts or accessories have been used on or in relation to the Product.

### LIMITATIONS

AL-KO makes no express warranties or representations other than set out in this warranty.

The repair or replacement of the Product or part of the Product is the absolute limit of AL-KO's liability under this express warranty.

### CONTACT

AL-KO International Pty Ltd  
67 Nathan Road, Dandenong South, Victoria, 3175  
Phone: (03) 9767 3700  
Email: info@alko.com.au





## **AL-KO INTERNATIONAL PTY LIMITED**

- VIC** 67-91 Nathan Road, Dandenong South 3175  
Ph: (03) 9767 3700 - Fax: (03) 9792 0877
- NSW** 26 Hallstrom Place, Wetherill Park, 2164  
Ph: (02) 8784 9400 - Fax: (02) 9725 4557
- QLD** 13 Union Circuit, Yatala 4207  
Ph: (07) 3386 6300 - Fax: (07) 3386 6399
- NZ** 1 Airpark Drive, Airpark Oaks, Mangere, Auckland  
Ph: (09) 255 5611 - Fax: (09) 255 5612

**To find out more from AL-KO International visit [www.alko.com.au](http://www.alko.com.au)**